



# Advances in Probing Technology for Capture of High Frequency Signals

LeCroy Corporation Booth 600 Intel Developers Forum Press and Analyst  
Contact: Dr. Michael Lauterbach, Director, Product Management

## Introduction

Measuring wideband signals such as PCI Express, Serial ATA and other types of fast analog and digital signals within a system almost always requires a high impedance probe. One is occasionally fortunate enough to be able to connect a high frequency signal directly to the input of a measuring instrument via a cable, but most signals must be observed within a functioning system to determine characteristics while the system is operating. Oscilloscope users in particular are very familiar with both active and passive probes that measure a voltage when the tip is touched to an exposed trace or terminal.

Most probes are single-ended, meaning that they measure a signal with respect to a common ground. Real grounds, however, are not common, necessitating a ground lead that connects the ground near the probe tip to the device under test. This type of probe will have difficulty measuring signals when the ground local to the signal is quite different (particularly at high frequencies) from the instrument ground. Ground can also vary significantly within the device being measured.

Designers can solve this problem by transmitting very high speed signals differentially to avoid problems with ground continuity, but this exacerbates the measurement challenges, since the measurement of only one signal in a differential pair with respect to ground is usually not a good representation of the differential signal. Engineers can use two probes to measure both differential signals and subtract them, but this will require two instrument channels, and depends on very precise matching between the two probes. In addition, as this paper will describe, this method will load down the circuit under test more than a true differential probe.

As good as they attempt to be, all high impedance probes will present a loading impedance to the signal being measured, resulting in distortion to this signal. This paper will explain why differential probes have inherently lower loading than singled-ended probes, and describe a new class of differential probes that have the lowest loading of any previous type of probe. The specific effects of probe loading on the signal under test will be quantified. Methods to evaluate the effects of probe loading will be shown as well.

## Loading Introduced by Single-ended Probes

Single ended probes have two input terminals – signal (tip) and ground. The equivalent circuit of such a probe will include series tip inductance, an input capacitance in parallel with the DC resistance, and the inductance of the ground lead. The ground lead inductance can be lumped together with the tip inductance to simplify the circuit.

The equivalent circuit of a typical active probe is given in Figure 1. The given inductance is shown as two inductors — a tip and a ground lead inductance. The ground lead inductor is usually dominant, and will change depending on how the user makes connection to the ground of the system under test.

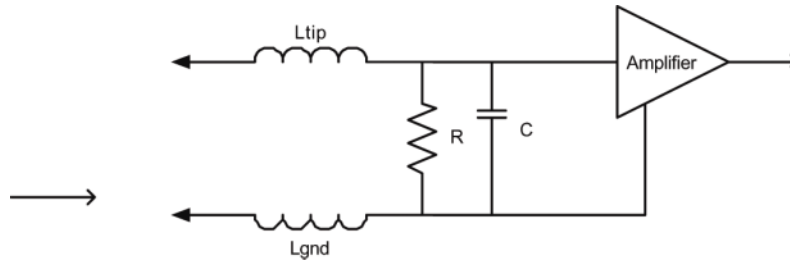

Figure 1

At low frequencies, this probe will load down the circuit under test by the resistance  $R$ . This is usually a rather large value, so this effect can be neglected. At higher frequencies, however, the capacitance starts to reduce the loading impedance, resulting in greater distortion of the signal being measured. At the frequency where the inductance resonates with the capacitance, the loading becomes  $0\omega$ , completely shorting the signal. In order to reduce the loading (increase the impedance of the probe), both the capacitance and inductance need to be made as small as possible.

A differential probe would consist of two single ended inputs and a differential amplifier, shown in Figure 2. Since the active circuitry only amplifies the difference between the two inputs, the common ground connection can be removed, along with the associated inductance. The remaining inductance is the sum of the two tip inductors, but since  $L_{tip}$  is usually much smaller than  $L_{gnd}$ , the loading inductance is reduced. The tip inductance is also a fixed quantity, not dependant on any sort of ground lead that might change from user to user. In addition, the capacitance is cut in half, since the loading capacitance is now the series combination of the original input capacitors.

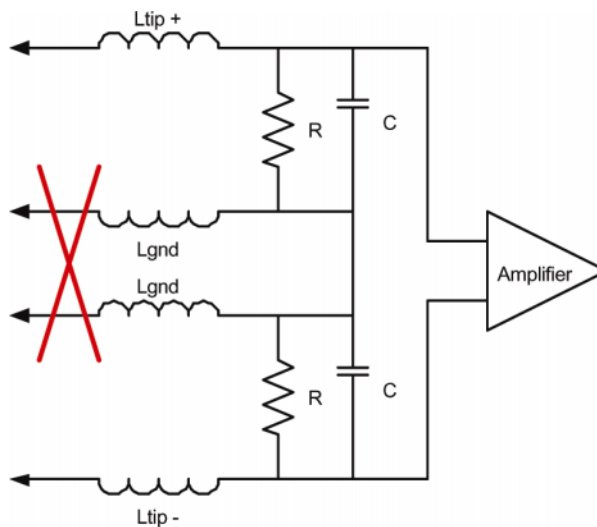

Figure 2

With the obvious benefits of such a differential design, one might ask why it has taken so long for equipment designers to create such a probe? The challenge, of course, is the design of a high bandwidth differential amplifier. Single-ended amplifiers are much simpler; they require fewer transistors, so they dissipate less power, are smaller, and can operate to higher frequencies.

In addition, there is added difficulty in attaching two high frequency tips to the input of an amplifier. Probe users are accustomed to browsing around their circuits, investigating different points to measure performance. Different circuits under test will require different placement and spacing of the leads, and any movement of these tips can drastically change the response of the probe at high frequencies. In order for common mode signals to be rejected, the characteristics of each tip must be identical, and it has been quite difficult to create physically useful tips that can remain matched as they are moved around.

The new WaveLink series of high bandwidth probes solves both of these problems. The most recent SiGe processes have enabled a very high bandwidth differential amplifier to be created that has the required high frequency performance, 7.5GHz in the case of the D600AT. The design also features a very symmetrical topology that insures that common voltages applied to the tips are rejected, even at the highest frequency of operation.

The problems associated with adjustable tips have been solved with a new patent pending input circuit that allows the tips to be connected to the amplifier with small transmission lines. The amplifier and tips are constructed on a flexible substrate, so that the tips can be moved. The user can now adjust the probe tips to exactly match the spacing of the signals that he wants to measure without causing any change to the probe's loading or frequency response.

### Effects of Probe Loading on Signals

Until just a few years ago, instrument manufacturers only mentioned the input resistance and capacitance of their probes. It was claimed that this was due to the fact that the inductance term is dominated by the users' ground leads, and they had little control over this connection. The result, however, was that the probe makers neglected all signal degrading effects of ground leads when specifying their probes. In fact, special low inductance fixtures would often be created to measure probe performance. Using such fixtures, a manufacturer could show frequency response and bandwidth performance that would be impossible to achieve in any real measurement situation (where an actual connection to ground must be made).

Looking more closely at the equivalent circuit shown in Figure 1, one can see that at the resonant frequency {given by  $1/(2\pi\sqrt{LC})$ } the input impedance of the probe will be 0 ohms – completely eliminating the signal being measured! Recently some manufacturers have become sensitive to this problem and created probes with more well behaved input characteristics. Figure 3 shows the equivalent circuit of one such probe (Probe A). This is one of many equivalent loading models given for this probe, depending on exactly what tip and ground lead is used. There is still a resonant frequency for this probe at approximately 2GHz, but the impedance at this frequency is limited by the resistors to about 165 ohms.

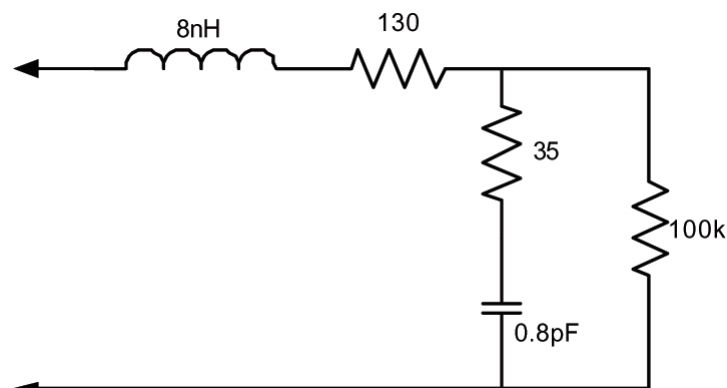

Figure 3

The equivalent circuit for the new WaveLink differential probes is shown in Figure 4 . While the design includes resistance to damp the impedance at resonance, it also is able to reduce the inductance term by the elimination of the ground lead inductance. The input capacitance is further reduced to extremely low levels, effectively moving the resonant frequency to approximately 7GHz, well beyond that of the single-ended probe.

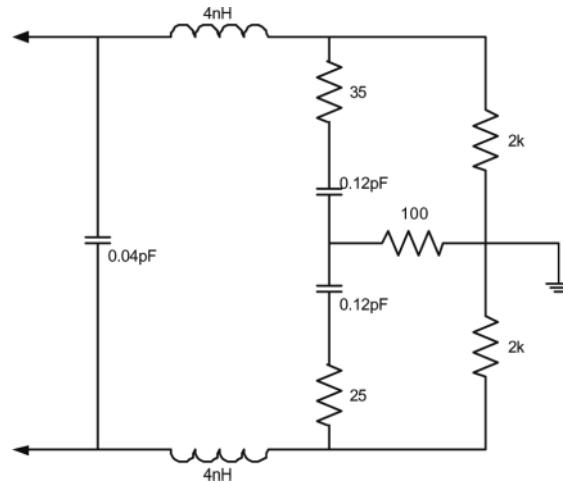
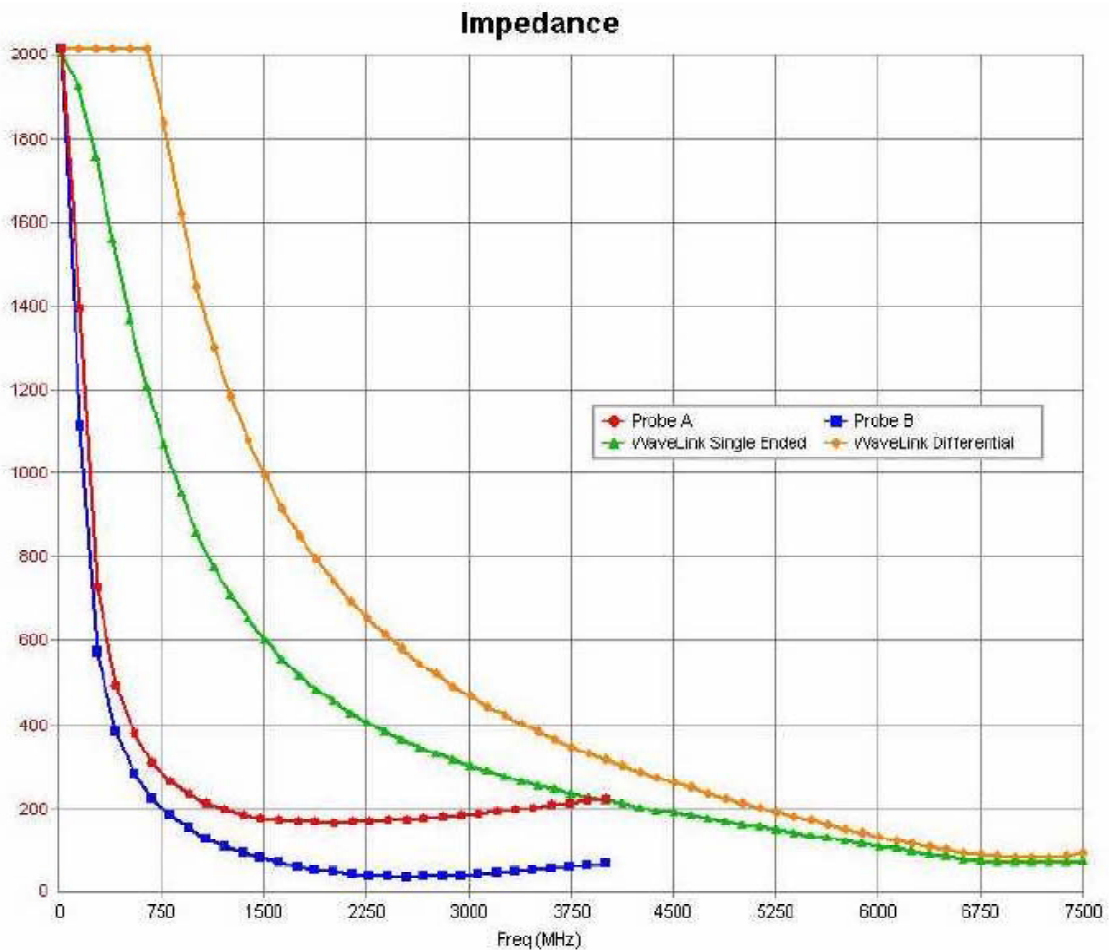

Figure 4

What is the effect of this new design on probe input impedance? The graph (Figure 5) below shows the impedance vs. frequency for Probe A above along with Probe B, made by another manufacturer that has not taken as much care to reduce the input resonant loading. On the same plot, the loading impedance of the new WaveLink probe is shown. Since this is a differential probe, there are two traces – the first shows the impedance when used as a single-ended probe (with the negative input used as a ground connection) and the second shows the loading impedance when driven from a balanced source. The traces are stopped at the maximum specified frequency of each probe.

One obvious difference between the WaveLink probe and the single ended probe is the lower DC resistance: 4k ohms differential vs. 100k ohms. While this might seem like a very significant difference, when the impedance vs. frequency plot is examined, one can see that for frequencies greater than a few 10s of MHz (virtually all frequencies of interest for such a probe), the loading impedance is dominated by the reactive components. The lower input capacitance provides the WaveLink probe with a much higher input impedance.



**Figure 5**

Determining the effect that this impedance will have on the signal being measured is not quite as simple, since this is partially dependant on the impedance of the circuit under test. For this reason, a plot of impedance vs. frequency is not enough; having an accurate equivalent circuit is vital so that the effects can be calculated for the specific circuit being measured.

In order to compare the performance of different probes, one usually plots the loading effects in a well defined and constant circuit. For example, the insertion loss introduced by each probe is shown in Figure 6 for an ideal 50 ohm environment. The insertion loss is expressed in dB; to express this as a voltage, one must divide the number by 20, and take anti- log. For example, the loss of 4.6dB that is caused by Probe B is a 41% reduction in amplitude. This could have drastic effects on the signal being probed.

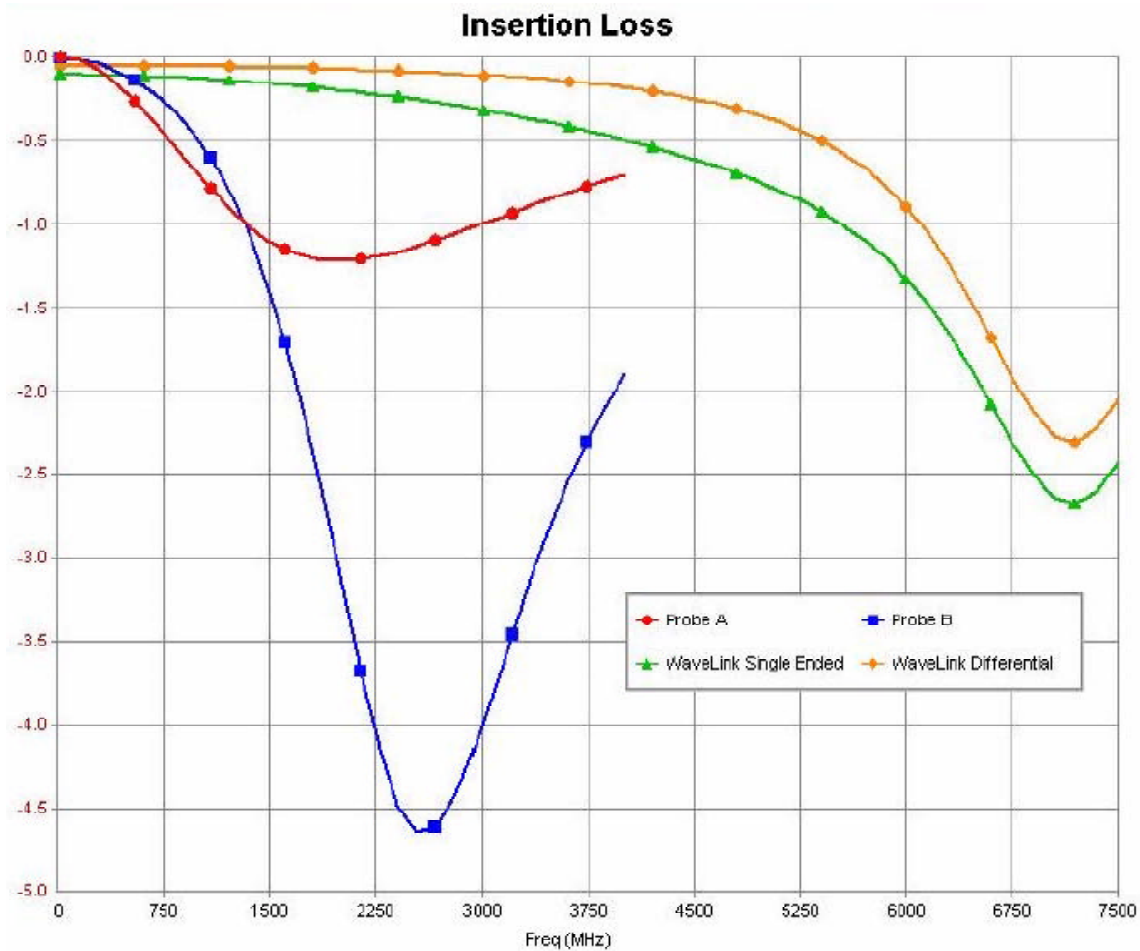

**Figure 6**

In addition to loss, timing errors that can be induced on the circuit being tested by the probe's impedance. The loading of the probe can induce delay to the signal being measured. This can be even more serious than amplitude loss, since these errors can propagate throughout the system. If several points are being monitored, each point could experience a time shift when the probe is placed on contact with the signal, and these delays will add.

Depending on the loading impedance of the probe, the delay might not be constant with frequency. This means that signals that have different edge rates (different frequency content) might be delayed by different amounts. When probes have a resonance with the input shifted from being capacitive to being inductive, the delay can shift. Even probes that attempt to reduce the amplitude effects of the LC resonance, will distort the time delay of a signal. The only real solution is to move the resonant frequency beyond the frequencies being tested.

In the frequency domain, timing shift is expressed as group delay. This is defined as the change in phase divided by the change in frequency. Ideal transmission lines will have constant group delay (meaning that the delay is independent of the frequency). Likewise, a capacitive load will have constant group delay. A more complex loading circuit, however, can exhibit delay that changes as the frequency content of the signal varies. This can induce deterministic jitter in a signal, simply by placing the probe in contact with the signal.

The group delay of the example probes is shown in Figure 7. The vertical scale is in nanoseconds. Note that, similarly to the amplitude loss, delay is also a function of the impedance of the circuit being measured. In addition, if one was to predict the effect that the probe was going to have on the signal, the specific characteristics of the signal would have to be included in the simulation.

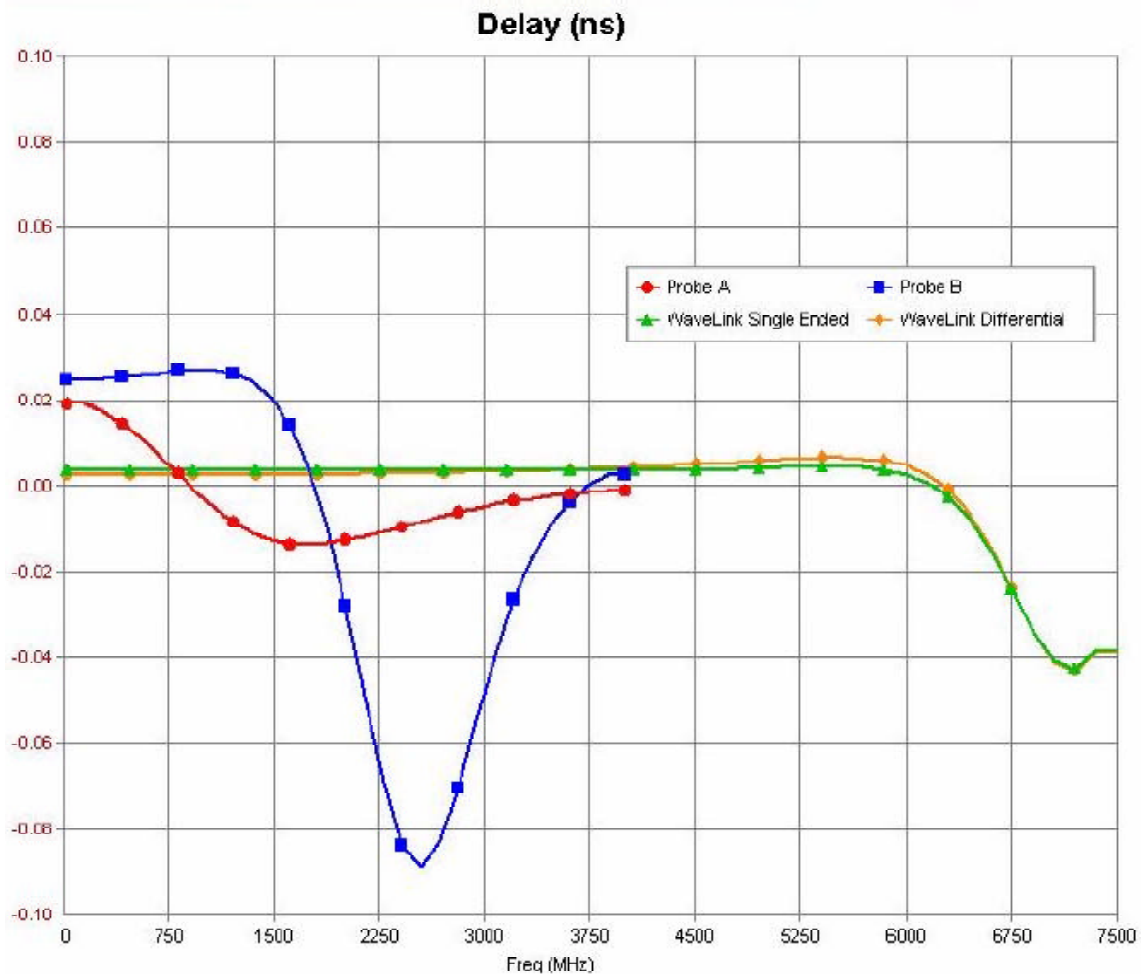

**Figure 7**

### How to Evaluate Loading Distortion

It is often difficult to determine the effects of probe loading on your signal. The simplest method is to connect your signal (or a representative signal) directly to the input of your measuring instrument through a fixture that will allow you to probe this signal. One such fixture is shown in the photo below (Figure 8). This is a 50 ohm microstrip transmission line, and will provide a very low distortion connection to the instrument. Using this fixture, one can measure the signal both with and without the probe attached to detect any change in signal shape or timing due to probe loading.

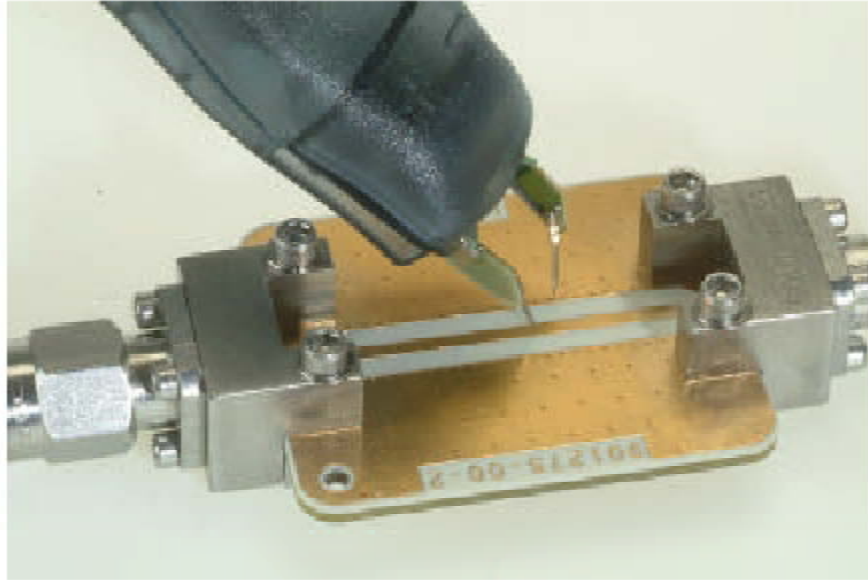

**Figure 8**

We can demonstrate this method by installing the fixture on the input of a LeCroy WaveMaster oscilloscope and displaying the signal with and without a probe attached to the traces of the fixture. The act of touching the probe to the signal should have minimal effect. Figure 9 demonstrates the result when the load of Probe A is placed across the signal.

To determine the effects of delay due to loading, the user must trigger the oscilloscope on an independent signal so that the trigger point will not shift as the probe is attached. The oscilloscope is set up to measure the amplitude and delay of the unloaded signal (stored in memory M1) as well as the loaded signal (displayed on channel 1). As with the previous test for the effect of probe loading on signal shape, the most desirable effect is none. The perfect probe will not change the shape of the rising edge or the timing of the edge relative to the trigger point. In this case, the leaning edge of the signal is attenuated, and the time is delayed by 7ps. Since we have seen that the group delay is not constant for such a probe, this value will change as the frequency content (risetime) of the signal changes.



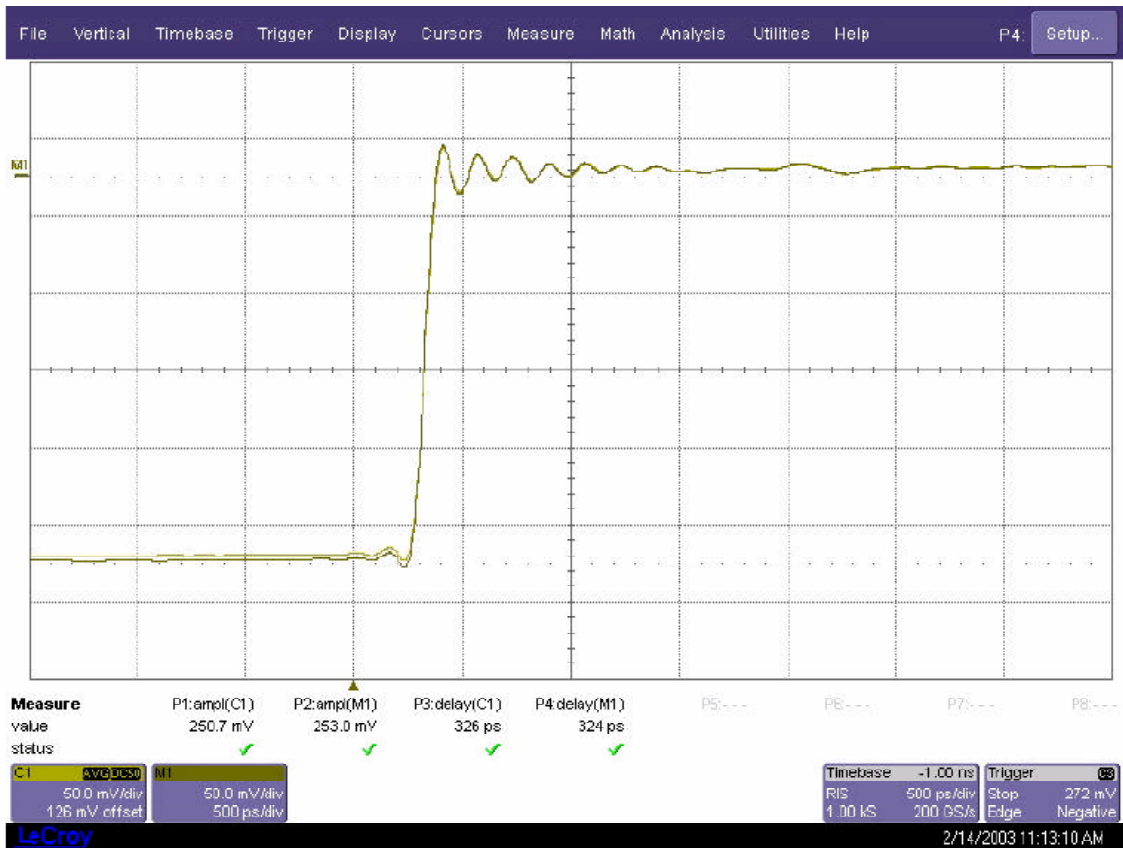

Figure 10

A new WaveLink probe is attached across the same test signal, and the resulting measurement is shown in Figure 10. There is a slight reduction of the signal amplitude due to the probe loading (<1%), but the leading edge of the signal is completely free of distortion. The delay induced by the probe's impedance is 2ps, and this value will not vary with signal frequency.

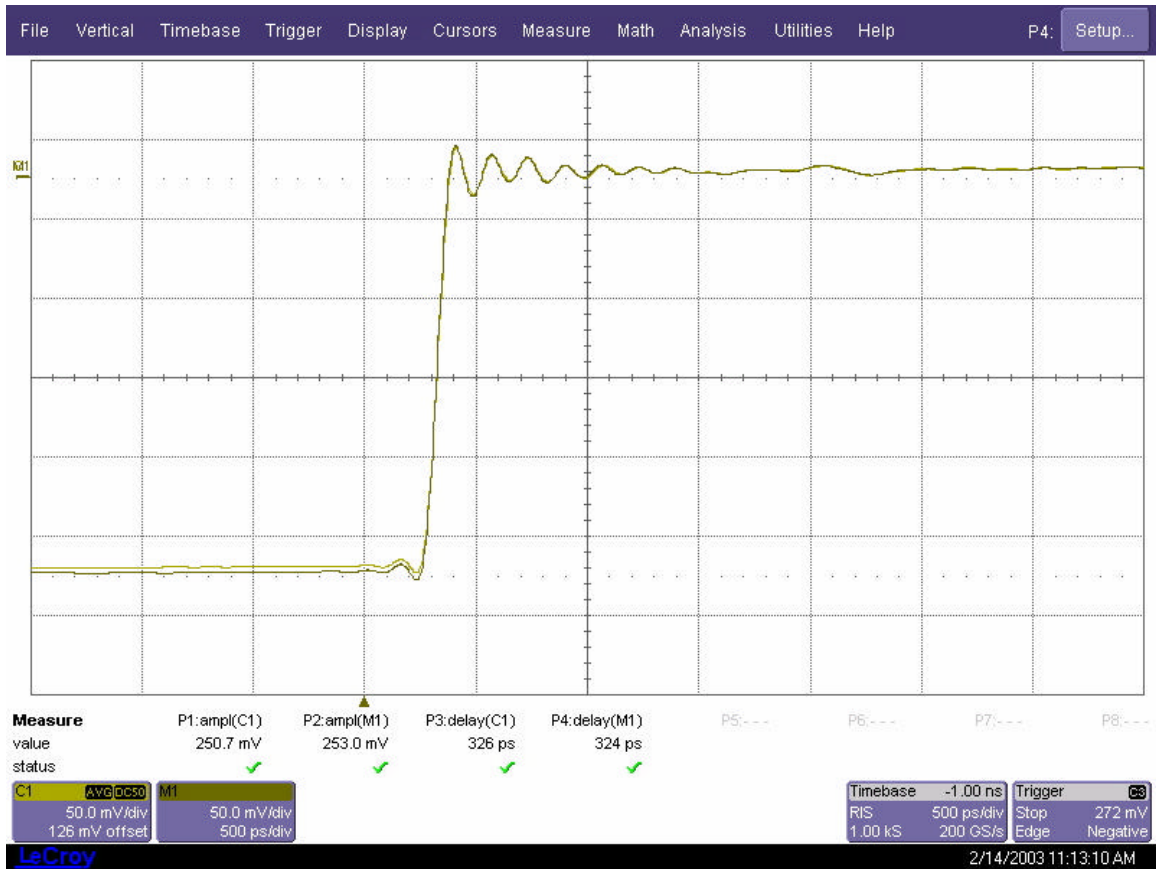

Figure 10

This same fixture can be used to make measurements in the frequency domain. The insertion loss of the signal through the test fixture can be measured, and the added insertion loss due to probe loading, as well as the group delay can be displayed.

## Conclusion

A probe's loading impedance can cause significant changes in both amplitude and timing to signals being measured. The lower a probe's loading impedance is, the more profound these changes will be, and the more dependent these changes are to the specific characteristics of the circuit being measured. These changes, particularly the time skew, can be particularly damaging since they can propagate through a functioning system to corrupt measurements made at other points in the system. An accurate model of a probe's input impedance is required to fully evaluate the effects that will be seen when the probe is used.

Differential probes have inherently lower loading, and now that the problems in creating a very high bandwidth differential amplifier (7.5GHz in this case) have been solved, all high frequency measurements will be best made with such a probe. The WaveLink series of probes has the least loading at these high frequencies of any probe available, providing the lowest distortion of test signals.